

Installation instructions

PROFILINE – industrial clocks, single-sided, square

Before installation of the clock please read the manual carefully.



References to the Instruction Manual

1. The information in this Instruction Manual can be changed at any time without previous notice.
2. This Instruction Manual has been composed with utmost care, in order to explain all details in respect of the operation of the product. Should you, nevertheless, have questions or discover errors in this Manual, please contact us.
3. We do not answer for direct or indirect damages, which could occur, when using this Manual
4. Please read the instructions carefully and start the setting-up of the product, only once you have correctly understood all information for the installation and of the operation.
5. The installation must only be carried out by skilled staff.
6. It is prohibited to reproduce, to store in a computer system or to transfer this publication in a way or another, even part of it. The copyright remains with all the rights with MOSER-BAER AG – CH 3454 Sumiswald / SWITZERLAND.

List of contents

Page

List of contents	2
1 Mounting guidelines	3
1.1 Fastening	3
1.2 Building Department / Authority Permit	4
1.3 Manner of fastening (WA or DA):	4
1.4 Opening clock	4
1.5 Closing clock	4
1.6 Cleaning	4
2 Electrical connections	4
2.1 Mains power supply	4
2.1.1 Electrical connections	5
2.2 Internal connections	5
2.3 Autonomous quartz clocks (MMM: Q02)	5
2.4 Autonomous radio controlled clocks with external DCF 77 radio receiver (R26)	6
2.5 Autonomous radio controlled clocks with external GPS – receiver (R51)	7
2.6 Slave clocks for minute impulses (I02, I06)	7
2.7 Slave clocks	8
3 Regulate the movement	8
3.1 Pulse controlled slave clocks (NU 90t / NU 90t SYN)	8
3.2 Autonomous radio controlled movements (BU 190t, MLU 190t, xTBU 190t, SU 190t)	9
4 Replacement of lamp and choke	9
4.1 Opening clock	9
4.2 Replace the lamp	9
4.3 Replacement of starter	9
4.4 Replacement of choke	9
4.5 Close clock	9
5 Valid documents	9
6 Mounting plates	10
6.1 Autonomous clock with illumination (MMM: Q02, R26, R51)	14
6.2 Slave clock with minute pulses w/o synchronous seconds (MMM: I02)	15
6.3 Slave clock with minute pulses with synchronous seconds (MMM: I06)	15
6.4 Slave clock for MOBALine (MMM: M04, M09)	16
6.5 Slave clock for MOBALine, mains powered (MMM: M06, M12)	16
6.6 Slave clock for DCF-77 – time code (MMM: R01, R04)	17
6.7 Slave clocks for serial telegram synchronization (MMM: T51, T53)	17
6.8 Slave clock for GPS (DCF) (MMM: R61, R63)	18

1 Mounting guidelines

1.1 Fastening

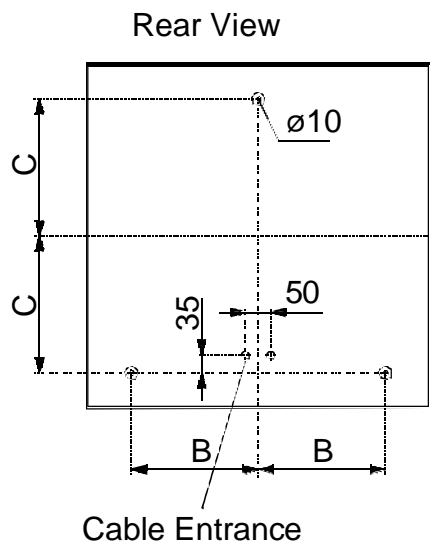
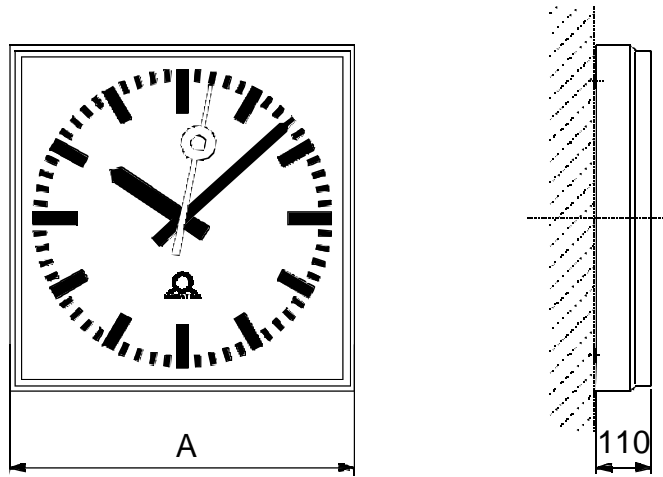

Nominal- \varnothing	Dimension in mm		
	A	B	C
400	446	155	175
500	546	205	225
600	646	255	275
800	846	355	375

1.2 Building Department / Authority Permit

If necessary a building department / authority permit should be requested before mounting.

1.3 Manner of fastening (WA or DA):

For wall, ceiling or pedestal fastening (W, D or S) set bolts or screws as described in chapter 1.1, for wall bracket (WA) resp. ceiling suspension (DA) set bolts or screws as described in chapter 1.2 (recommended bolt Ø 12 mm).

For pole mounting, prepare central pole taking in account wind load stressing. Feed electrical line from inside pole as wall bracket (WA and SM), ceiling suspension (DA) or central pole (ZM) and then fix the clock.

Warning: Before mounting, all wire must be disconnected from mains!

1.4 Opening clock

Disconnect mains 230V/50Hz BEFORE start working at clock inside!

For opening clock, unscrew the two screws of the profiles on the side of the clock. Remove the profile without jam, it is protected against fall out by a chain.

Pull out dial (with movement) lateral out of the profiles.



Self setting movements: Do not touch hands!

1.5 Closing clock

Introduce dial lateral in the profile, close profile and fix the clock with the two fixing screw.

Pay attention that cables do not cause shadowing on illuminated dial.

1.6 Cleaning

Clean glass with a humid cloth. Do not use solvent, evaporating or organic detergent.

2 Electrical connections

2.1 Mains power supply

The mains power supply for illumination and clock movement may only be connected from a licensed electrician.

Use the same phase with only one fuse for illumination and movement.

The timing switch for the illumination has to be installed with respect to the constructional situation. The power supply for the movements has to be permanent.

Warning:

Disconnect mains 230V/50Hz BEFORE start working at clock inside!

For cable entry of the line for minute impulse resp. the DCF-77 – radio receiver a second membrane rubber bushing is prepared.

Connections and plug-in connections see mounting plates (pages 9-15).

2.1.1 Electrical connections

- **Autonomous clocks with quartz controlled clock (QU)**
PLQ(B).QU.50, PLQ(B).QU.60, PLQ(B).QU.80
see mounting plate with clock movement QU 192 page 14/19
- **Autonomous clocks with DCF radio telegram (FWU)**
PLQ(B).FWU.50, PLQ(B).FWU.60, PLQ(B).FWU.80
see mounting plate with clock movement FWU 192 page 14/19
- **Autonomous clocks with GPS radio telegram (GU)**
PLQ(B).GU.50, PLQ(B).GU, PLQ(B).GU.80
see mounting plate with clock movement GU 192 page 14/19
- **Slave clocks for minute impulses (A, F)**
PLQ(B).A.50, PLQ(B).A.60, PLQ(B).A.80
see mounting plate with clock movement NU 90t page 15/19
PLQ(B).F.50, PLQ(B).F.60, PLQ(B).F.80
see mounting plate with clock movement NU 90t / SYN page 15/19
- **Slave clocks with MOBALine w/o mains connection (SAM, SFM)**
PLQ(B).SAM.50, PLQ(B).SAM.60, PLQ(B).SAM.80
see mounting plate with clock movement MLU 190t page 16/19
PLQ(B).SAM.40, PLQ(B).SAM.50, PLQ(B).SAM.60, PLQ(B).SAM.80
see mounting plate with clock movement MLU 190t S 48 page 16/19
- **Slave clocks with MOBALine and mains connection (SAM230, SFM230)**
PLQ(B).SAM.40, PLQ(B).SAM.50, PLQ(B).SAM.60, PLQ(B).SAM.80
see mounting plate with clock movement MLU 190t 230 page 16/19
PLQ(B).SFMxxx.40, PLQ(B).SFMxxx.50, PLQ(B).SFMxxx.60, PLQ(B).SFMxxx.80
see mounting plate with clock movement MLU 190t S 230 page 16/19
- **Slave clocks for DCF- or serial telegram and mains connection (SAA, SFA)**
PLQ(B).SAA.40, PLQ(B).SAA.50, PLQ(B).SAA.60, PLQ(B).SAA.80
see mounting plate with clock movement BU 190t 230 page 17/19
PLQ(B).SFA.40, PLQ(B).SFA.50, PLQ(B).SFA.60, PLQ(B).SFA.80
see mounting plate with clock movement BU 190t S 230 page 17/19
- **Slave clocks with audio frequency clock movement and mains connection (SAT, SFT)**
PLQ(B).SAT.40, PLQ(B).SAT.50, PLQ(B).SAT.60, PLQ(B).SAT.80
see mounting plate with clock movement ATBU 190t 230 page 17/19
PLQ(B).SFT.40, PLQ(B).SFT.50, PLQ(B).SFT.60, PLQ(B).SFT.80
see mounting plate with clock movement ITBU 190t S 230 page 17/19

2.2 Internal connections

The internal wiring is made in factory. It's important not to modify the internal wiring.

2.3 Autonomous quartz clocks (MMM: Q02)

The movement is driven by battery.

Battery life with lithium battery (250394): 6 – 7 years.

2.4 Autonomous radio controlled clocks with external DCF 77 radio receiver (R26)

Order-reference: PLQ(B).FWU.E

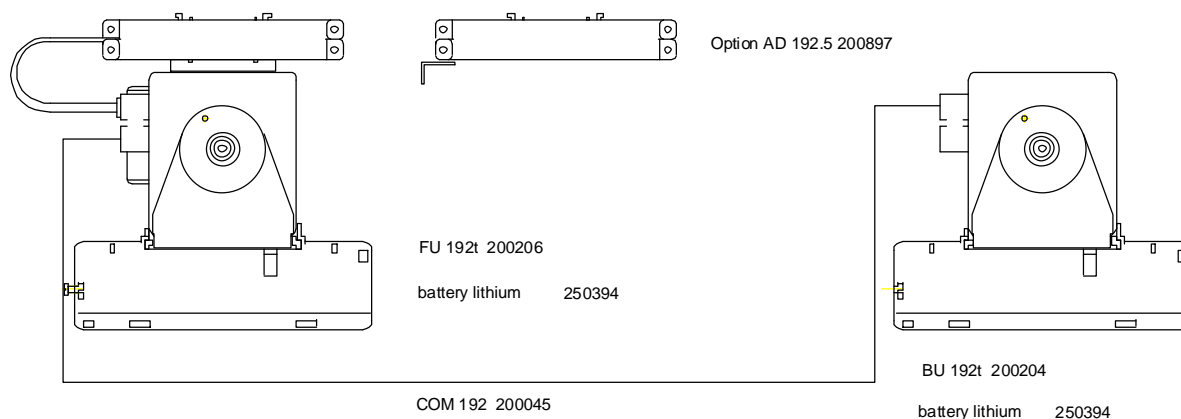

The DCF 77 radio receiver AD 192 is as normal fitted on the movement and is used for indoor mounting only. For clocks with illumination, the external radio receiver AD 192.5 has to be used. If the reception quality is bad, it's recommended to use the external radio receiver too. The radio receiver AD 192.5 is delivered with protection IP 54 and 5m cable for outdoor mounting.

Radio controlled movement FU 192 is driven with two mono cells (only for indoor use), resp. a lithium battery or a power supply, protected against power-fail by an accumulator.

To check the reception quality, press the reset button on backside of the movement. Close the clock. The hands are set to the 12-hour position and if the reception quality is good enough, after 5 to 10 minutes, the clock sets on actual time. If not, repeat the procedure.

Profiline clocks with radio-controlled movements FU 192 are delivered with a separate initiation instruction. Battery life with lithium battery (250394): 6 – 7 years.

2.5 Autonomous radio controlled clocks with external GPS – receiver (R51)

Order-reference: PLQ(B).GU.xx

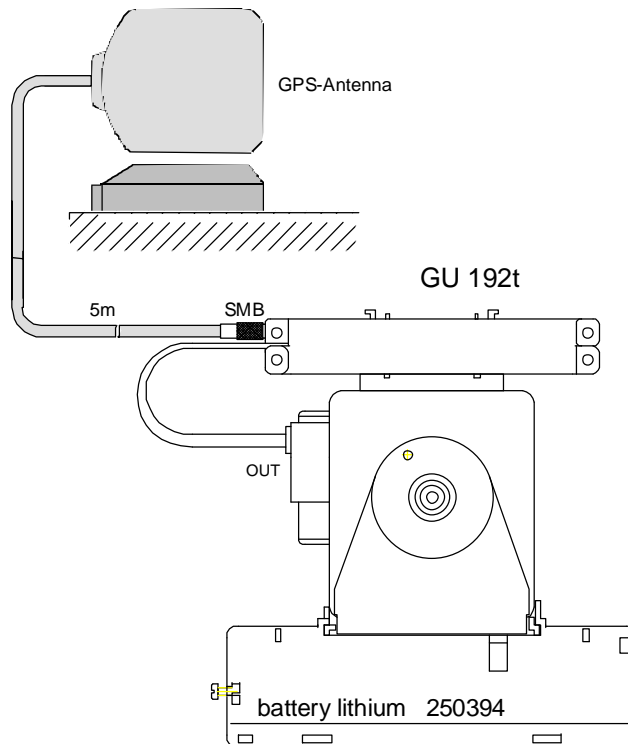

The antenna must be mounted outdoors in horizontal position and with a viewing angle of 90°.

PROFILINE–clocks with autonomous radio controlled movements GU 192 are delivered with a separate, detailed manual (BE – 800 304).

Battery life with lithium battery (250394): > 5 years.

2.6 Slave clocks for minute impulses (I02, I06)

NU90t, NU 90t/SYN

Order-reference: PLQ(B).A.E, PLQ(B).F.E

- Operating voltage switch (C) on back side of movement:

The operating voltage is factory set to 24 VDC.

If other voltage required, set DIP – switch according to diagram on backside of movement.

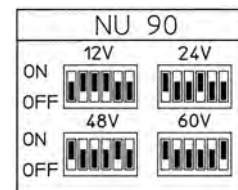

2.7 Slave clocks

Significant Documents

Slave clocks for DCF- or serial telegram and mains power supply (SAA, SFA)

PLQ(B).SAA.50, PLQ(B).SAA.60, PLQ(B).SAA.80
manual with movement BU 190t 230

BE – 800 603

PLQ(B).SFA.50, PLQ(B).SFA.60, PLQ(B).SFA.80
manual with movement BU 190t S 230

BE – 800 602

Slave clocks for MOBALine and mains power supply (SAM230, SFM230)

PLQ(B).SAM230.50, PLQ(B).SAM230.60, PLQ(B).SAM230.80
manual with movement MLU 190t 230

BE – 800 622

PLQ(B).SFM230.50, PLQ(B).SFM230.60, PLQ(B).SFM230.80
manual with movement MLU 190t S 230

BE – 800 565

Slave clocks for MOBALine without mains power supply (SAM, SFM)

PLQ(B).SAM.50, PLQ(B).SAM.60, PLQ(B).SAM.80
manual with movement MLU 190t

BE – 800 642

PLQ(B).SFM.50, PLQ(B).SFM.60, PLQ(B).SFM.80
manual with movement MLU 190t S 48

BE – 800 621

Slave clocks for audio frequency time code movement and mains power supply (SAT, SFT)

PLQ(B).SAT.50, PLQ(B).SAT.60, PLQ(B).SAT.80
manual with movement ATBU 190t 230

BE – 800 390

PLQ(B).SFT.50, PLQ(B).SFT.60, PLQ(B).SFT.80
manual with movement ITBU 190t S 230

BE – 800 390

3 Regulate the movement

3.1 Pulse controlled slave clocks (NU 90t / NU 90t SYN)

Push button (A) and turn, until hour and minute – hands shows desired time.
Never turn the second hand manually, as this will damage the movement.
Also, the minute hand may only be turned in clockwise direction.
Hand will be set with each minute pulse!

If there would be a difference of 1 min. between master clock and secondary clock time, move the plug (B) to the opposite pair of pins to reverse polarity and set minute hand 2 minutes forwards.

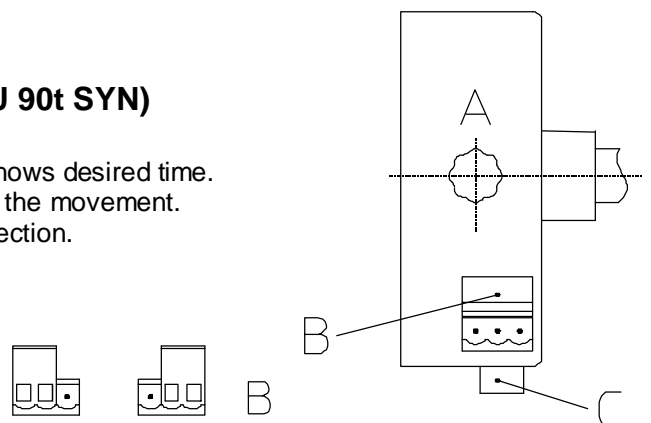

3.2 Autonomous radio controlled movements (BU 190t, MLU 190t, xTBU 190t, SU 190t)

No time settings needed, clock will set up automatically to current time.

Movements are set by factory to standard run mode (DIP switch for 12:00 position in OFF position).

If a clock does not run to correct time, set 12:00 position DIP switch to ON and check, if the hands are stopping at 12:00 position exactly (if not, remove the clock hands and fix them exactly at 12:00 position).

Correct time and guaranteed time and power reserve, as well as precision of the clock can only be guaranteed after 2-3 days of working.

For further information read the documentation of respective movements (see 2.7).

4 Replacement of lamp and choke

As far as the replacement of lamp and choke, the clock is maintenance-free.

4.1 Opening clock

Find fixing screw on lower part of housing, unscrew for about 8 mm.

Lift front part and make sure (with a wooden stick) that the clock remains open.

Warning:

Disconnect mains 230V/50Hz BEFORE start working at clock inside!

4.2 Replace the lamp

PLQ(B).Ex.50 SYLVANIA CIRCLINE, 305 mm Ø, FC 32W/154, daylight

PLQ(B).Ex.60/80 SYLVANIA CIRCLINE, 413 mm Ø, FC 40W/154, daylight
or OSRAM ring shaped LUMILUX, cool white L40/21-840C

4.3 Replacement of starter

SYLVANIA FS 11 or OSRAM ST 111 (4-80 W)

4.4 Replacement of choke

TRIDONIC.ATCO: EC 36 LC501 K, Class EEI = B2

4.5 Close clock

Remove the wooden stick, close the clock and fix the clock with the fixing screw.

5 Valid documents

Movements xBU 190t xxx	see chapter 2.7
Movements NU 90t/SYN	BE – 800 143
Movements NU 90t	BE – 800 142
DCF – receiver AD 450	TE – 800 116

6 Mounting plates

Only mounting plates for slave clock models with illumination are shown. For clocks w/o illumination, shorter plates are used w/o choke and w/o connection ring shape.

Back panel PL1.40.Q1....:

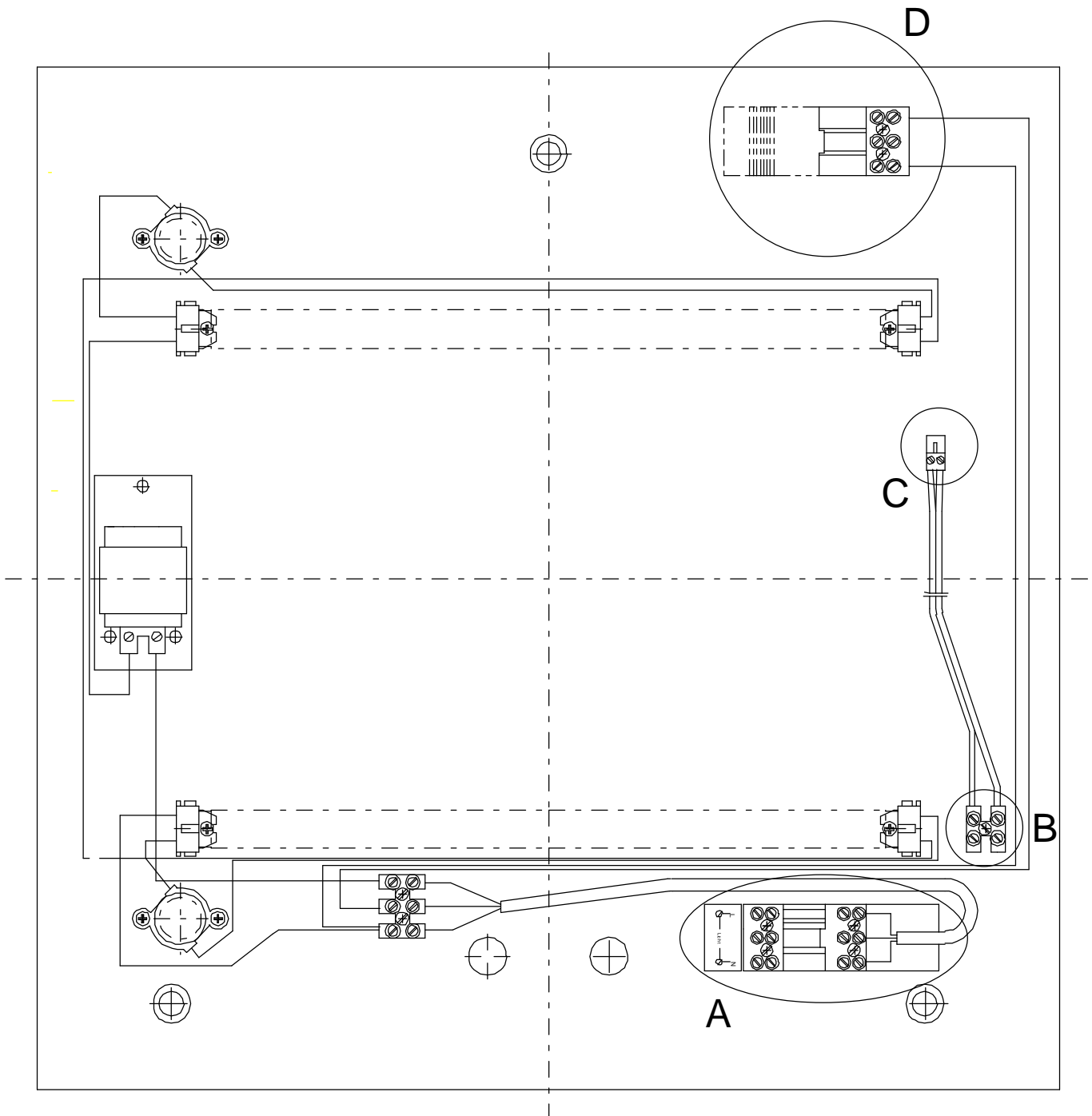

Back panel PL1.50.Q1....:

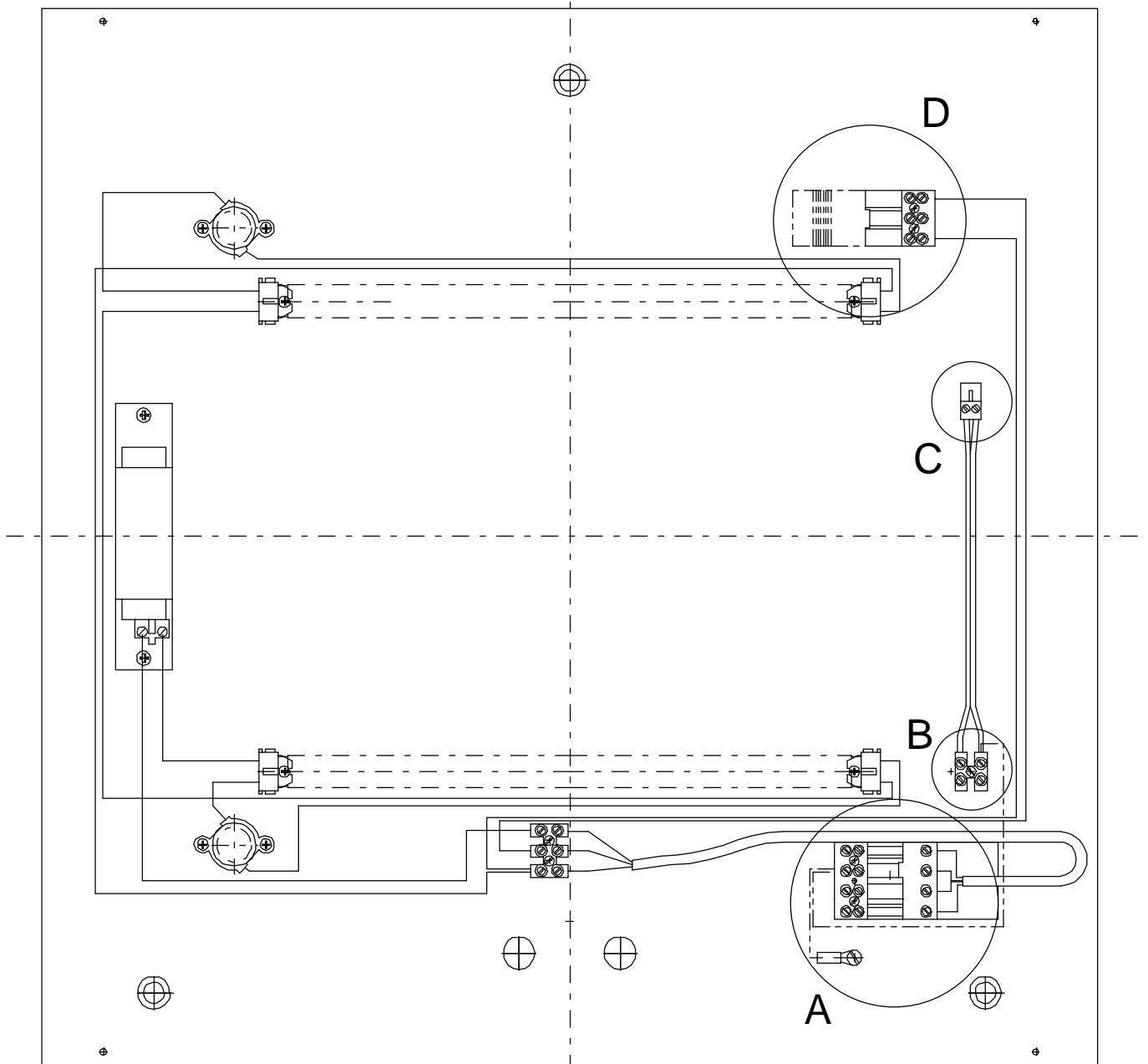

Back panel PL1.60.Q1...:

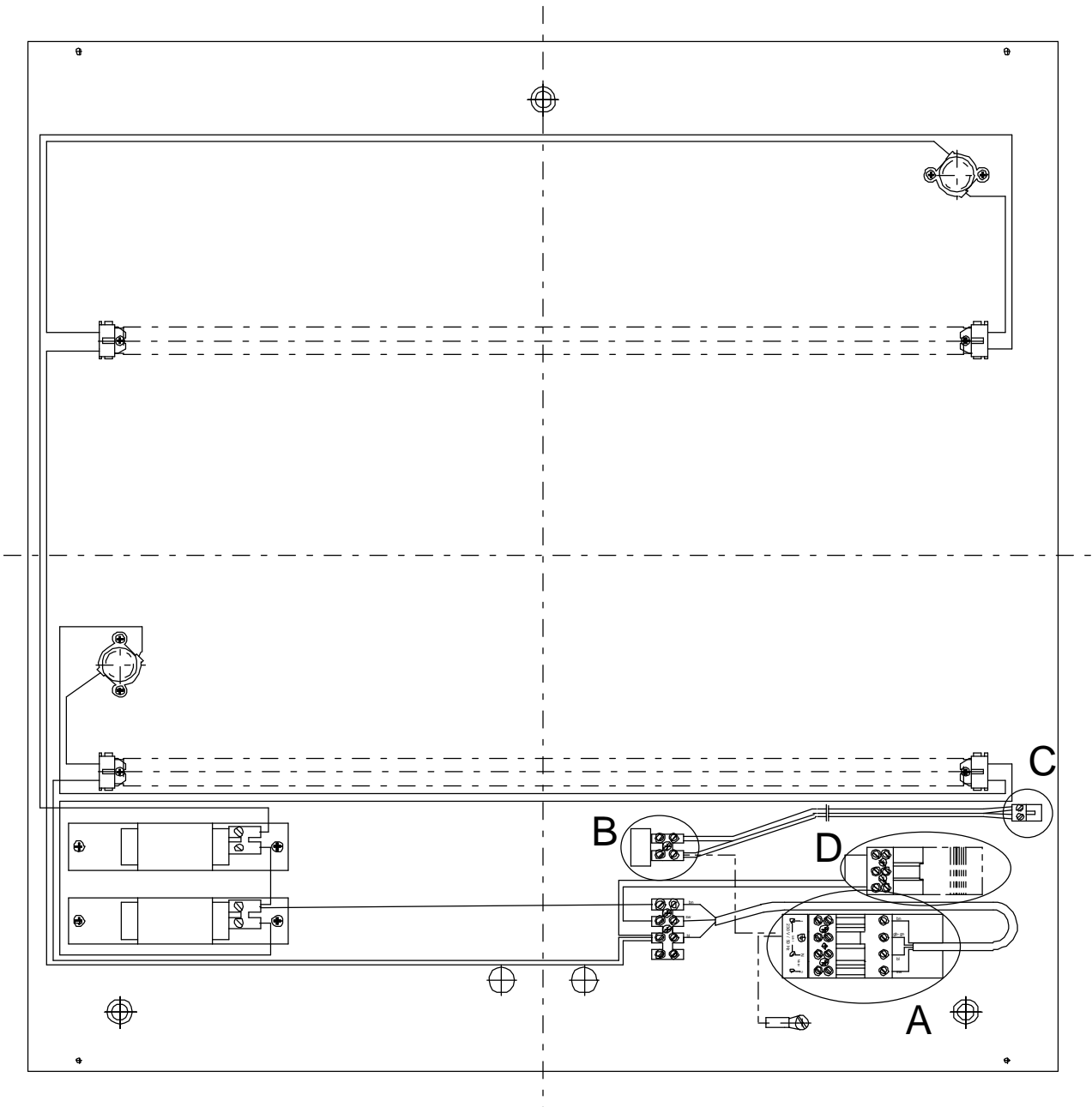

Back panel PL1.80.Q1...:

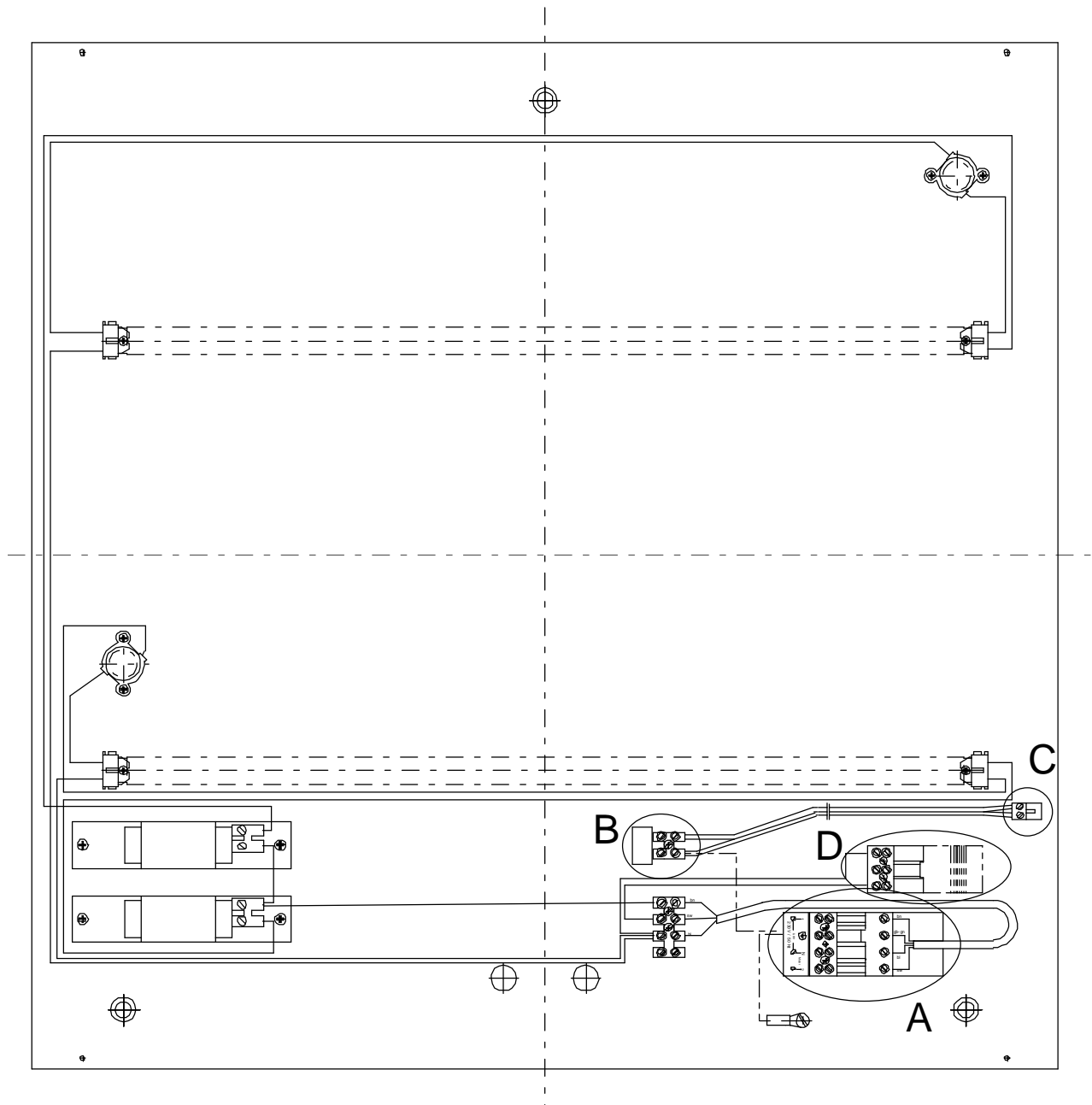

6.1 Autonomous clock with illumination (MMM: Q02, R26, R51)

Movement codes (MMM): Q02: QU 192
R26: FWU 192
R51: GU 192

Order reference PL1.xx.Q1.MMM...

Input supply illumination

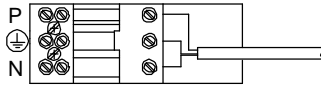

Plug A

Cascade:

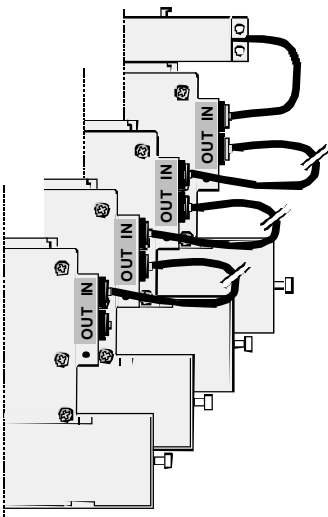

Cascading means that a number of movements will be connected in series.

Up to three slave movements BU 192 can be connected to one master movement.

As master movement the following type can be used:

- FU 192
- QU 192
- BU 192 mit serieller Synchronisation (with IF 494)

The cascading is done by means of a cascade cable COM 192 (length 1m), enabling to synchronize 4 movements with only one reference signal. After starting-up the time synchronization for all movements will follow in a few seconds only. Should the time for the master movement change during the normal operation, the time take-over for each connected movement will take about 2 minutes, which means totally about 8 minutes. This is also valid for the daylight saving time change.

6.2 Slave clock with minute pulses w/o synchronous seconds (MMM: I02)

Movement codes (MMM): I02: NU 90t

Order reference PL1.xx.Q1.I02...

Input supply illumination

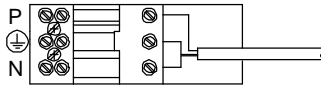

Plug A

Movement

input minute pulses



Plug C

plug B

6.3 Slave clock with minute pulses with synchronous seconds (MMM: I06)

Movement codes (MMM): I06: NU 90t/SYN

Order reference PL1.xx.Q1.I06...

Input supply movement and illumination

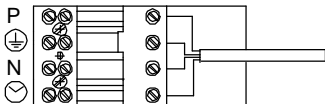

Plug A

Movement

input minute pulses



Plug C

plug B

Supply movement

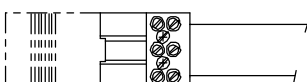

Plug D

6.4 Slave clock for MOBALine (MMM: M04, M09)

Movement codes (MMM): M04: MLU 190t
M09: MLU 190t S 48

Order reference PL1.xx.Q1.MMM...

Input supply illumination

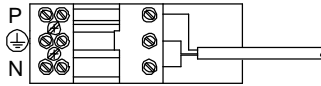

Plug A

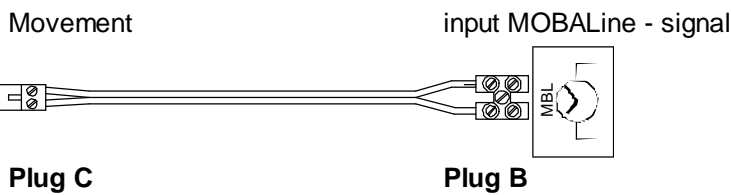

Plug C

Plug B

6.5 Slave clock for MOBALine, mains powered (MMM: M06, M12)

Movement codes (MMM): M06: MLU 190t 230
M12: MLU 190t S 230

Order reference PL1.xx.Q1.MMM...

Input supply movement and illumination

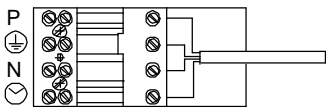

Plug A

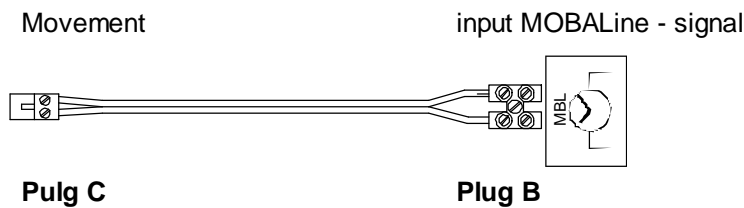

Plug C

Plug B

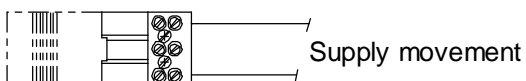

Plug D

6.6 Slave clock for DCF-77 – time code (MMM: R01, R04)

Movement codes (MMM): R01: BU 190t 230
R04: BU 190t S 230

Order reference PL1.xx.Q1.MMM...

Input supply movement and illumination

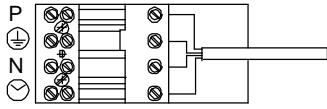

Plug A

Movement input DCF - signal



Plug C

Plug B

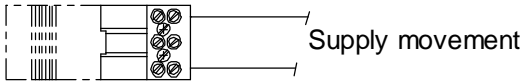

Plug D

6.7 Slave clocks for serial telegram synchronization (MMM: T51, T53)

Movement codes (MMM): T51: ATBU 190t 230
T53: ITBU 190t S 230

Order reference PL1.xx.Q1.MMM...

Input supply movement and illumination

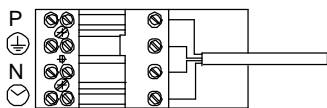

Plug A

Movement input time code

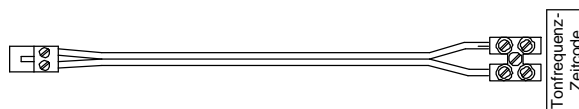

Plug C

Plug B

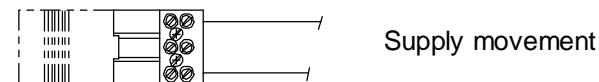

Plug D

6.8 Slave clock for GPS (DCF) (MMM: R61, R63)

Movement codes (MMM): R61: BU 190t 230 + PS24 (power supply for GPS)
 R63: BU 190t S 230 + PS24 (power supply for GPS)

Order reference PL1.xx.Q1.MMM...

GPS 4500 not included.

Input supply movement and illumination

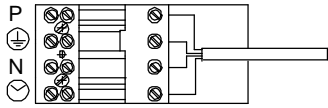

Plug A

Input DCF – signal from GPS

Movement / Clock side

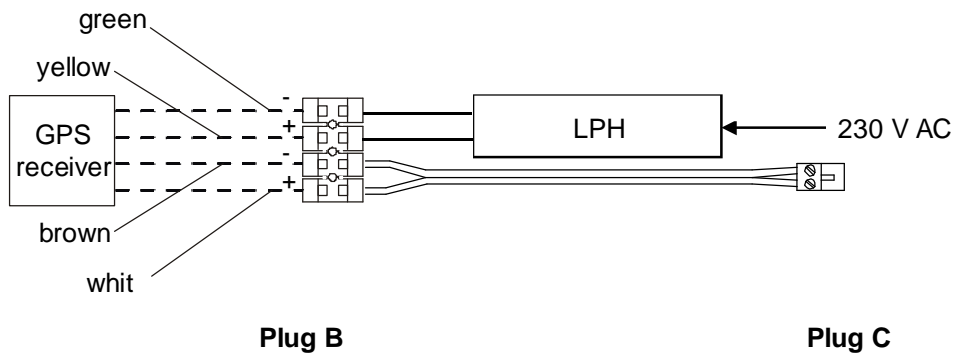

Plug B

Plug C

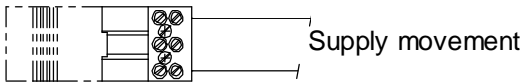

Plug D

HEADQUARTERS / PRODUCTION

MOSER-BAER AG
Spitalstrasse 7, CH-3454 Sumiswald
Tel. +41 34 432 46 46 / Fax +41 34 432 46 99
moserbaer@mobatime.com / www.mobatime.com

SALES WORLDWIDE

MOSER-BAER SA EXPORT DIVISION
19 ch. du Champ-des-Filles, CH-1228 Plan-les-Ouates
Tel. +41 22 884 96 11 / Fax + 41 22 884 96 90
export@mobatime.com / www.mobatime.com

SALES SWITZERLAND

MOBATIME AG
Stettbachstrasse 5, CH-8600 Dübendorf
Tel. +41 44 802 75 75 / Fax +41 44 802 75 65
info-d@mobatime.ch / www.mobatime.ch

MOBATIME SA
En Budron H 20, CH-1052 Le Mont-sur-Lausanne
Tél. +41 21 654 33 50 / Fax +41 21 654 33 69
info-f@mobatime.ch / www.mobatime.ch

SALES GERMANY, AUSTRIA

BÜRK MOBATIME GmbH
Postfach 3760, D-78026 VS-Schwenningen
Steinkirchring 46, D-78056 VS-Schwenningen
Tel. +49 7720 8535 0 / Fax +49 7720 8535 11
buerk@buerk-mobatime.de / www.buerk-mobatime.de