

# Installation and Operating Instructions

## DMU 140

**Movement for MOBALine, RS485 time code, DCF, MSF and GPS receiver for outdoor clocks up to Ø 140 cm.**

Please read these instructions carefully before installation.

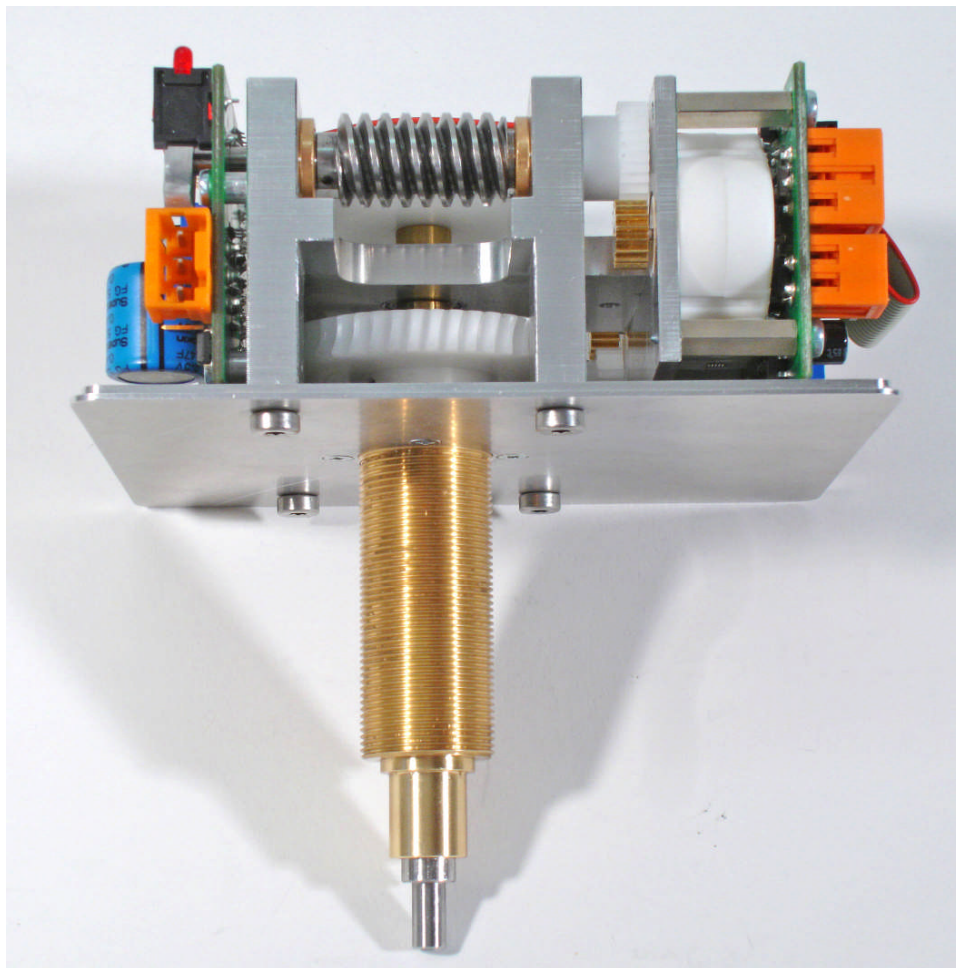

### **Certification of the Producer**

#### **STANDARDS**

The clock movement DMU 140 has been developed and produced in accordance with the EU Standards 89 / 336 / EU



### **References to the Instruction Manual**

1. The information in this Instruction Manual can be changed at any time without previous notice.
2. This Instruction Manual has been composed with utmost care, in order to explain all details in respect of the operation of the product. Should you, nevertheless, have questions or discover errors in this Manual, please contact us.
3. We do not answer for direct or indirect damages, which could occur, when using this Manual.
4. Please read the instructions carefully and start the setting-up of the product, only once you have correctly understood all information for the installation and of the operation.
5. The installation must only be carried out by skilled staff.
6. It is prohibited to reproduce, to store in a computer system or to transfer this publication in a way or another, even part of it. The copyright remains with all the rights with BÜRK MOBATIME GmbH, D-78026 VS-Schwenningen and MOSER-BAER AG – CH 3454 Sumiswald / SWITZERLAND.

# Contents

<b>1. Dimensions, definitions .....</b>	<b>4</b>
<b>2. Installation guidelines .....</b>	<b>5</b>
2.1 Installation of DMU 140 clock movements .....	5
2.2 Installation of hands and commissioning.....	5
2.2.1 Hand installation .....	5
2.2.2 Commissioning and checking hand position .....	5
2.3 View and wiring .....	6
2.4 Setting the synchronization mode and commissioning.....	6
2.4.1 Power supply voltage.....	6
2.4.2 Receiver wiring .....	7
2.4.3 Connection to main clocks.....	7
2.4.4 RS-485 terminating resistor .....	7
2.4.5 DIP switches .....	8
2.4.6 Synchronization .....	8
2.4.7 Cascading wiring option.....	8
<b>3. Function description .....</b>	<b>9</b>
<b>4. Standard Time Zone Table .....</b>	<b>10</b>
<b>5. Technical data:.....</b>	<b>12</b>
5.1 Plug wiring.....	13
5.1.1 RS-485.....	13
5.1.2 DCF In/Out.....	13

# 1. Dimensions, definitions

**Caution.** The DMU 140 is suitable for indoor and outdoor clocks to a max. Ø 140 cm. The hands must be covered by a glass face. The movements cannot be used for a facade clock with unprotected hands.

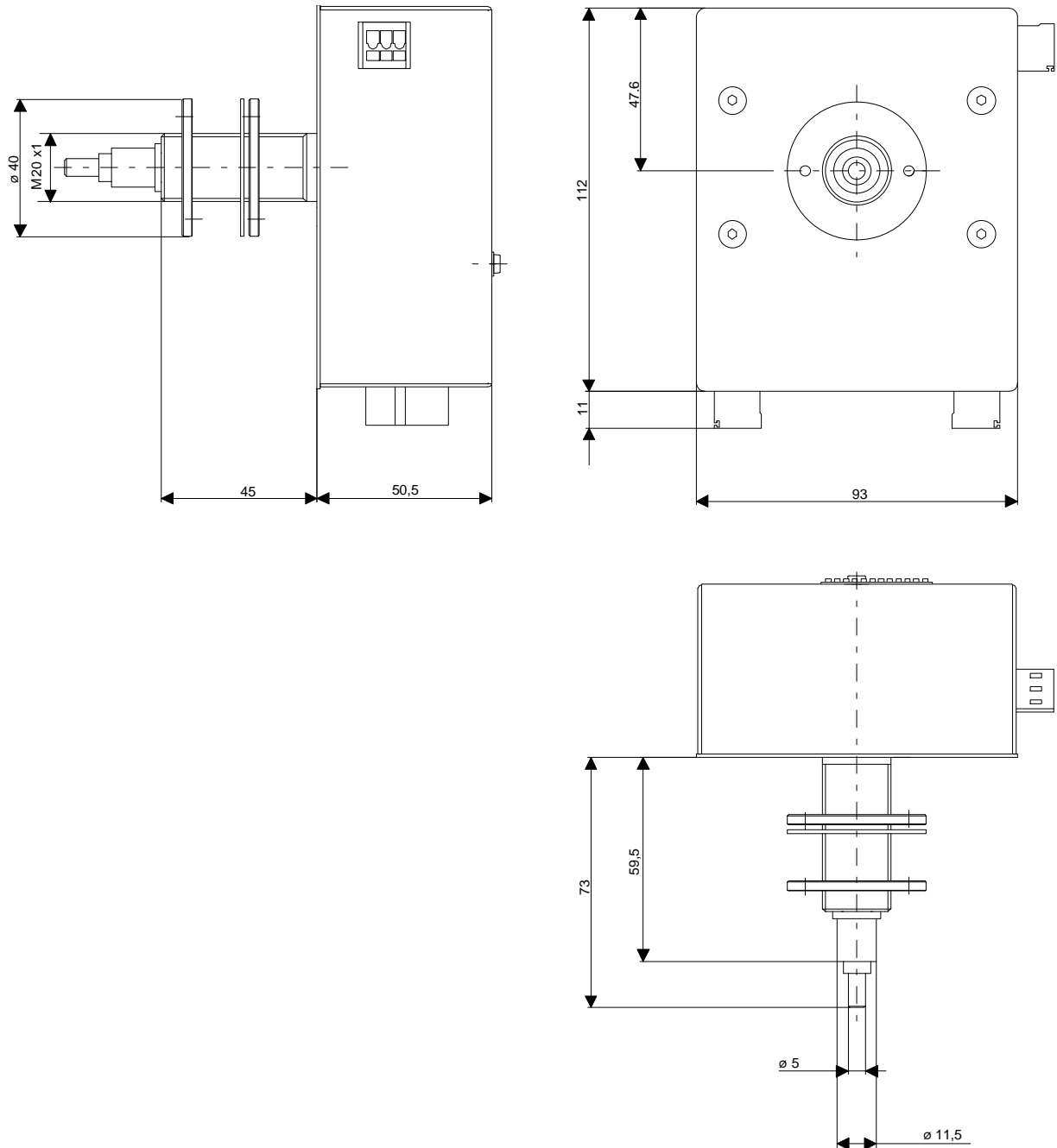

**Fig. 1**

## 2. Installation guidelines

### 2.1 Installation of DMU 140 clock movements

The dial must be adequately rugged. The installation drill hole must have a diameter of 20 mm.

The movements must be mounted vertically.

Fig. 2 shows the position of the components.

The washer nut (2) M20 x 1 is to be tightened carefully with a special spanner accessory and torque wrench using a torque of 4.5 Nm +/- 0.2 Nm.

#### Caution:

Do not turn the movements any further after the washer nut (2) has been tightened in place.

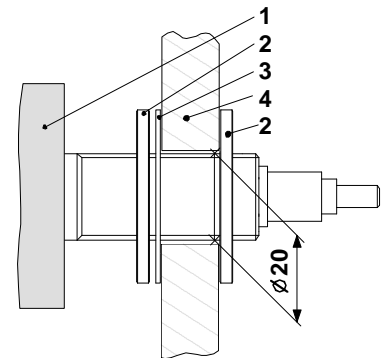

Fig. 2

- 1 Clock movements
- 2 Washer nut
- 3 Rubber washer
- 4 Clock face

### 2.2 Installation of hands and commissioning

#### 2.2.1 Hand installation

The hour and minute hand axles are positioned at 12:00 ex works. They must be inserted on the axles and pressed down to the stop (X). They must then be tightened in place without twisting the axles. See Fig. 3.

The 12:00 position must be checked in each movements after installing the hands (chapter 2.2.2)

#### 2.2.2 Commissioning and checking hand position

- Set DIP switch 1 to **ON** (12:00 position, Fig. 5)
- Connect *MOBALine* or DC power. The clock will turn to the 12:00 position.
  - Are the hands exactly at the 12:00 position?
- If not then carefully loosen, adjust and retighten them (do not twist the axle).
  - Recheck the 12:00 position (by briefly interrupting the power supply)
- If it's correct, continue with chapter 2.4 Mode Settings

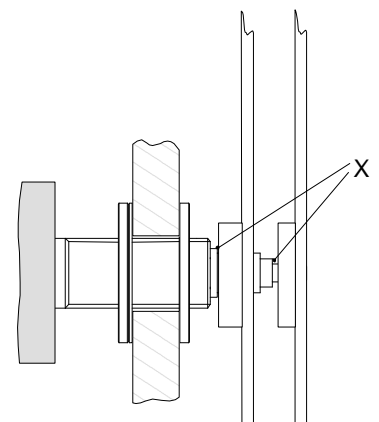

Fig. 3

## 2.3 View and wiring

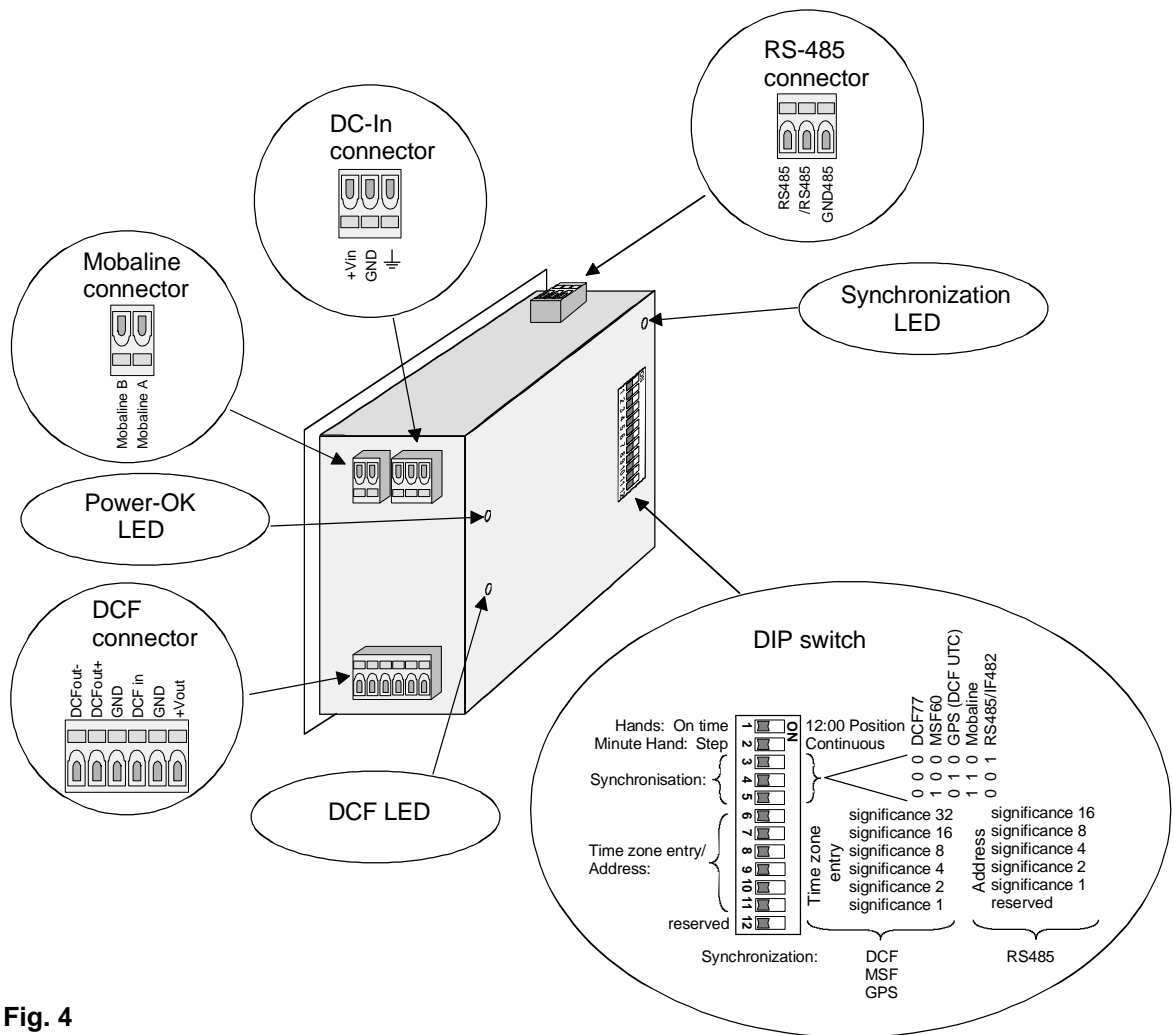

Fig. 4

## 2.4 Setting the synchronization mode and commissioning

### 2.4.1 Power supply voltage

This is via *MOBALine* or 10-30 V DC. To ensure DCF/MSF reception is as trouble-free as possible, functional earthing is essential.

Power supply via mains power module

External 24 V power supply

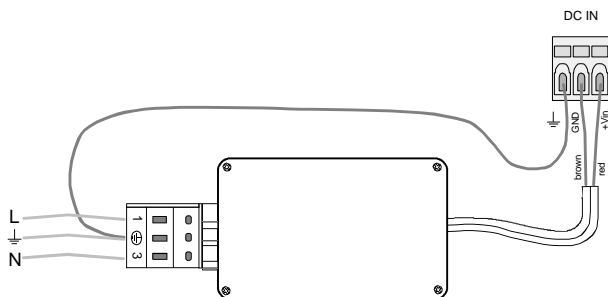

Fig. 5

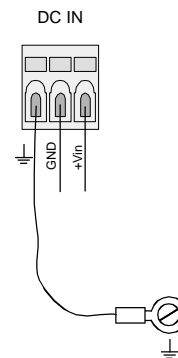

Fig. 6

## 2.4.2 Receiver wiring

- The signal is shown by DCF-LED
- Correct synchronization is shown by the synchronization LED.

DCF receiver

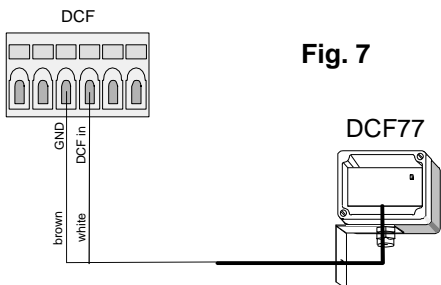

Fig. 7

GPS receiver

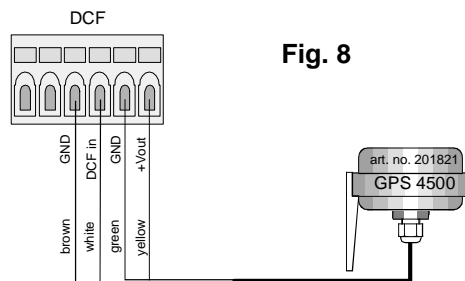

Fig. 8

## 2.4.3 Connection to main clocks

- Correct synchronization is shown by the synchronization LED.

MOBALine

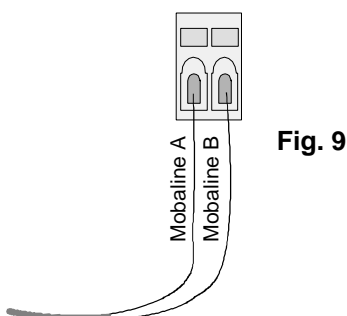

Fig. 9

RS-485

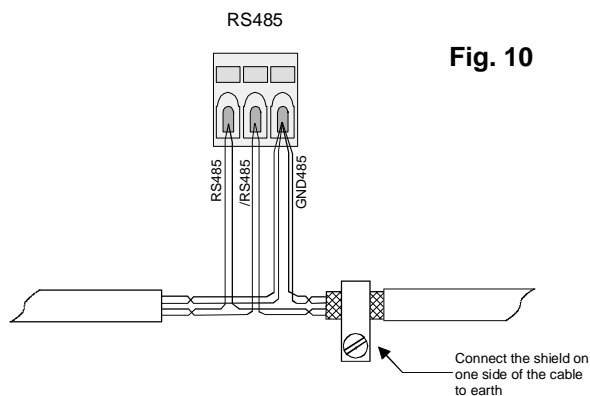

Fig. 10

## 2.4.4 RS-485 terminating resistor

The termination resistor must be activated in clock movements at the end of a RS-485 line. Open the clock movements cover cautiously to do so. The jumper is on the pc-board with DIP switches. Replug the X8 jumpers X8 to activate the terminating resistor.

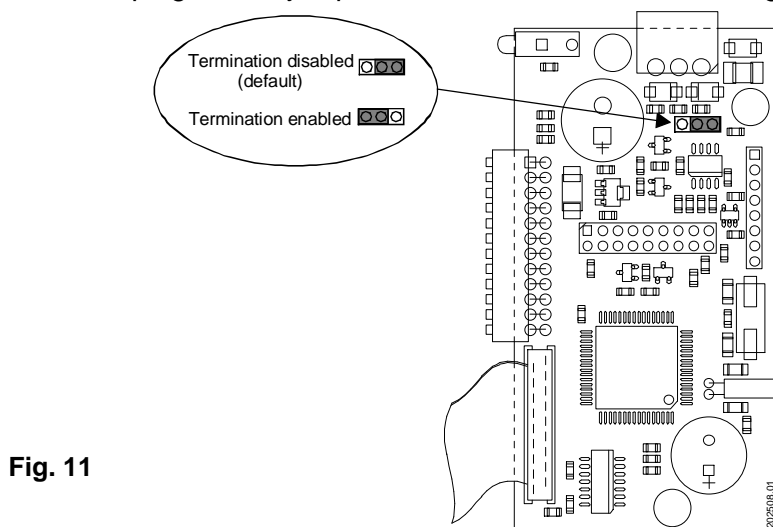

Fig. 11

### 2.4.5 DIP switches

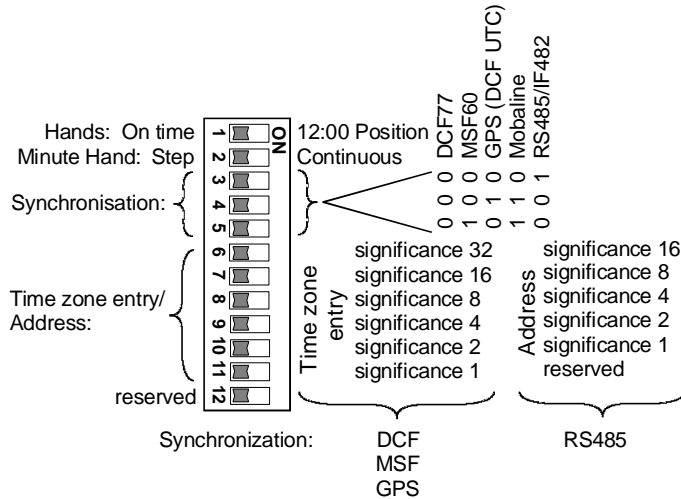

Fig. 12

### 2.4.6 Synchronization

- Set the DIP switches 3,4,5 as the synchronization mode dictates.
- Set time zone and RS-485 address using the DIP switches 6 -11. This setting is not needed in some synchronization modes.
- DCF reception is shown by a regularly blinking of the DCF LED.
- Correct synchronization is shown by the Synchronization LED.
- After a brief period (see chapter 5) the clock will start running to current line time.

Example of calculating time zone and address setting:

1 2 3 4 5 6 7 8 9 10 11 12	NO								
			Time zone		Address				
		DIP switch 11	Off	Value 1	0				
		DIP switch 10	On	Value 2	2	Value 1	1		
		DIP switch 9	On	Value 4	4	Value 2	2		
		DIP switch 8	Off	Value 8	0	Value 4	0		
		DIP switch 7	On	Value 16	16	Value 8	8		
		DIP switch 6	Off	Value 32	0	Value 16	0		
				Total	22	Total	11		
				<b>= Time zone</b>	<b>22</b>	<b>= Address</b>	<b>11</b>		

### 2.4.7 Cascading wiring option

The DCF time code can be connected to the next movement via DCF-out. Synchronization in cascaded movements must be set to GPS (DCF UTC).

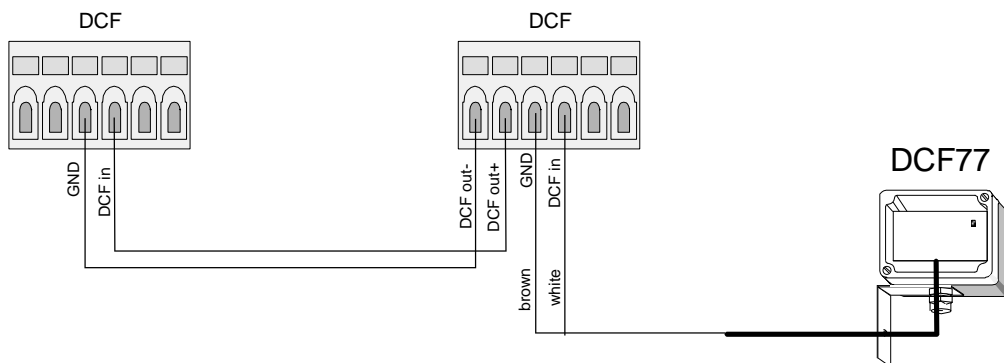

Fig. 13



### 3. Function description

Self-setting movement for hour and minute hands. For self-setting clocks indoors and outdoors (under glass covers) with a face diameter of up to 140 cm with or without lighting.

- **MOBALine, DCF77, MFS60** time code or controlled by MB-485-protocol via **RS-485** with automatic time take over.
- Synchronization from a master clock or with DCF, MSF or GPS receiver.
- DC power supply to a GPS receiver.
- Operating mode, synchronization, time zone and RS-485 address selectable by DIP switch.
- Self-setting, 12:00 position monitored by sensors with correction facility.
- Two motors with forwards and backwards capabilities for rapid adjustment.
- Power-saving mode with *MOBALine* - only one motor in use, with priority given to the minute motor.
- Lack of *MOBALine* or RS-485 time signal during 24 hours is shown by resetting the hands to 12:00 o'clock position.
- Lack of DCF77 or MSF 60 time signal during 7 days (7 x 24 h) is shown by resetting the hands to 12:00 o'clock position.
- Immediate adjustment to the correct time after power interruptions of up to 10 h based on internal quartz clock (battery-less time keeping).
- DIP switch 2 is used to select the minute hand function mode, continuous or in minute steps. *MOBALine* ignores this switch. The running mode is selected via the line mode of the master clock, with half-minute steps becoming minute steps.
- Output of a synthetic DCF77 code, when movement is synchronized with DCF77 or MSF 60 (UTC).
- Status LED for power supply, DCF impulses and synchronization.

## 4. Standard Time Zone Table

Time zone entries in the standard season table (version 9.0).

Time zone	City / State	UTC Offset	DST Change	Standard → DST	DST → Standard
00	UTC (GMT), Monrovia, Casablanca	0	No		
01	London, Dublin, Edinburgh, Lisbon	0	Yes	Last Sun. Mar. (01:00)	Last Sun. Oct. (02:00)
02	Brussels, Amsterdam, Berlin, Bern, Copenhagen, Madrid, Oslo, Paris, Rome, Stockholm, Vienna, Belgrade, Bratislava, Bu- dapest, Liubliana, Prague, Sarajevo, Sofia, Vilnius, Warsaw, Zagreb	+1	Yes	Last Sun. Mar. (02:00)	Last Sun. Oct. (03:00)
03	Athens, Istanbul, Minsk, Helsinki, Riga, Tallinn, Kaliningrad	+2	Yes	Last Sun. Mar. (03:00)	Last Sun. Oct. (04:00)
04	Bucharest, Romania	+2	Yes	Last Sun. Mar. (03:00)	Last Sun. Oct. (04:00)
05	Cairo, Pretoria, Harare	+2	No		
06	Dhaka	+6	Yes	Wed. 31. Mar. (22:59) (2010)	Sun. 31. Oct. (23:59) (2010)
07	Tel Aviv	+2	Yes	Last Fri. Mar. (02:00)	2 <sup>nd</sup> Sun. Oct. (02:00) (2010)
08	Kuwait City	+3	No		
09	Moscow, St. Petersburg, Volgograd	+3	Yes	Last Sun. Mar. (02:00)	Last Sun. Oct. (03:00)
10	Tehran	+3.5	Yes	Sun. 21. Mar. (00:00) (2010)	Tue. 21. Sep. (00:00) (2010)
11	Abu Dhabi, Muscat, Tbilisi	+4	No		
12	Kabul	+4.5	No		
13	Yekaterinburg, Russia	+5	Yes	Last Sun. Mar. (02:00)	Last Sun. Oct. (03:00)
14	Tashkent	+5	No		
15	Mumbai, Calcutta, Ma- dras, New Delhi, Colombo	+5.5	No		
16	Astana, Thimphu	+6	No		
17	Bangkok, Hanoi, Jakarta	+7	No		
18	Beijing, Chongqing, Hong kong, Singapore, Taipei, Urumqi	+8	No		
19	Tokyo, Osaka, Sapporo, Seoul	+9	No		
20	Yakutsk, Russia	+9	Yes	Last Sun. Mar. (02:00)	Last Sun. Oct. (03:00)
21	South Australia: Adelaide	+9.5	Yes	1 <sup>st</sup> Sun. Oct (02:00)	1 <sup>st</sup> Sun. Apr. (03:00)
22	Northern Territory: Darwin	+9.5	No		
23	Queensland: Brisbane, Guam, Port Moresby	+10	No		
24	NSW, Victoria: Sydney, Canberra, Melbourne	+10	Yes	1 <sup>st</sup> Sun. Oct. (02:00)	1 <sup>st</sup> Sun. Apr. (03:00)
25	Tasmania: Hobart	+10	Yes	1 <sup>st</sup> Sun. Oct. (02:00)	1 <sup>st</sup> Sun. Apr. (03:00)
26	Vladivostok	+10	Yes	Last Sun. Mar. (02:00)	Last Sun. Oct. (03:00)
27	Solomon Is. , New Caledonia	+11	No		

28	Auckland, Wellington	+12	Yes	Last Sun. Sep. (02:00)	1 <sup>st</sup> Sun. Apr. (03:00)
29	Marshall Is.	+12	No		
30	Azores	-1	Yes	Last Sun. Mar. (00:00)	Last Sun. Oct. (01:00)
31	Middle Atlantic	-2	No		
32	Brasilia	-3	Yes	3 <sup>rd</sup> Sun. Oct. (00:00)	3 <sup>rd</sup> Sun. Feb. (00:00) (2010)
33	Buenos Aires	-3	No		
34	Newfoundland, Labrador	-3.5	Yes	2 <sup>nd</sup> Sun. Mar. (00:01)	1 <sup>st</sup> Sun. Nov. (00:01)
35	Atlantic Time (Canada)	-4	Yes	2 <sup>nd</sup> Sun. Mar. (02:00)	1 <sup>st</sup> Sun. Nov. (02:00)
36	La Paz	-4	No		
37	Bogota, Lima, Quito	-5	No		
38	New York, Eastern Time (US & Canada)	-5	Yes	2 <sup>nd</sup> Sun. Mar. (02:00)	1 <sup>st</sup> Sun. Nov. (02:00)
39	Chicago, Central Time (US & Canada)	-6	Yes	2 <sup>nd</sup> Sun. Mar. (02:00)	1 <sup>st</sup> Sun. Nov. (02:00)
40	Tegucigalpa, Honduras	-6	No		
41	Phoenix, Arizona	-7	No		
42	Denver, Mountain Time	-7	Yes	2 <sup>nd</sup> Sun. Mar. (02:00)	1 <sup>st</sup> Sun. Nov. (02:00)
43	Los Angeles, Pacific Time	-8	Yes	2 <sup>nd</sup> Sun. Mar. (02:00)	1 <sup>st</sup> Sun. Nov. (02:00)
44	Anchorage, Alaska (US)	-9	Yes	2 <sup>nd</sup> Sun. Mar. (02:00)	1 <sup>st</sup> Sun. Nov. (02:00)
45	Honolulu, Hawaii (US)	-10	No		
46	Midway Islands (US)	-11	No		
47	Mexico City, Mexico	-6	Yes	1 <sup>st</sup> Sun. Apr. (02:00)	Last Sun. Oct. (02:00)
48	Samara, Russia	+4	Yes	Last Sun. Mar. (02:00)	Last Sun. Oct. (03:00)
49	Novosibirsk, Russia	+6	Yes	Last Sun. Mar. (02:00)	Last Sun. Oct. (03:00)
50	Krasnoyarsk, Russia	+7	Yes	Last Sun. Mar. (02:00)	Last Sun. Oct. (03:00)
51	Irkutsk, Russia	+8	Yes	Last Sun. Mar. (02:00)	Last Sun. Oct. (03:00)
52	Magadan, Russia	+11	Yes	Last Sun. Mar. (02:00)	Last Sun. Oct. (03:00)
53	Anadyr, Russia	+12	Yes	Last Sun. Mar. (02:00)	Last Sun. Oct. (03:00)
54	Ittoqqortoormiit, Greenland	-1	Yes	Last Sun. Mar. (00:00)	Last Sun. Oct. (01:00)
55	Nuuk, Greenland	-3	Yes	Last Sat. Mar. (22:00)	Last Sat. Oct. (23:00)
56	Qaanaaq, Greenland	-4	Yes	2 <sup>nd</sup> Sun. Mar. (02:00)	1 <sup>st</sup> Sun. Nov. (02:00)
57	Western Australia: Perth	+8	No		
58	Caracas	-4.5	No		
59	CET standard time	+1	No		
60	Santiago, Chile	-4	Yes	2 <sup>nd</sup> Sun. Oct. (00:00)	2 <sup>nd</sup> Sun. Mar. (00:00)
61	Chile, Easter Island	-6	Yes	2 <sup>nd</sup> Sat. Oct. (22:00)	2 <sup>nd</sup> Sat. Mar. (22:00)
62	Baku	+4	Yes	Last Sun. Mar. (04:00)	Last Sun. Oct. (05:00)
63	Islamabad, Karachi, Pakistan	+5	No	Thu. 15. Apr. (00:00) (2010)	Sun. 31. Oct. (00:00) (2010)
64	Apia, Samoa	-11	Yes	Last Sun. Sep. (00:00)	First Sun. Apr. (00:00) (2011)

**Legend:**

UTC: Universal Time Coordinate, equivalent to GMT  
DST: Daylight Saving Time  
DST Change: Daylight Saving Time changeover  
Standard → DST: Time change from Standard time (Winter time) to Summer time  
DST → Standard: Time change from Summer time to Standard time (Winter time)

**Example:**

2<sup>nd</sup> last Sun. Mar. (02:00) Switch over on the penultimate Sunday in March at 02.00 hours local time.



**Attention:**

As usual, the time table is adapted each year. You can download the newest time table from our homepage: [www.mobatime.com](http://www.mobatime.com) → Downloads → Moba-Software → Time Zone Table. If the delivered device contains a newer version as showed in this manual, it's recommended to check the time zone entries.

## 5. Technical data:

	<b>DMU 140</b>
Synchronization	MOBALine, GPS, DCF, MSF, RS 485
Adjustment times Running time to start position MOBALine time to read in DCF or MSF reading in time Readjustment time Adjustment time from Summer to Winter Time	Max. 3 minutes Max. 3 minutes Max. 6 minutes Max. 3 minutes Max. 0.5 minutes
Minute hand operating mode	Continuous or 1 step every 60 s Configurable in MOBALine using line mode - in other synchronization modes using DIP switch 2
Hour hand operating mode	1 step every 60 s
Power supply: DC on DC In or Mobaline	10 - 30 V DC
Power consumption at 24 VDC	< 1.5 V A (<60 mA)
Power consumption from MOBALine	max. 80mA
DCF input	Current source max. 32 mA
DCF output, UTC output is only active with DCF, MSF and GPS synchronization	Optocoupler output protected against incorrect poling Max. 35 mA voltage drop approximately 2 V @ 20 mA
DC Out: DC power for GPS receiver	10 – 30 V depending on supply voltage Max. 200 mA protected by Multifuse
Running reserve in case of power loss	None
Time keeping based on internal quartz clock	> 10 h
Number of motors	2 (hrs. /mins.)
Dial diameter	80 - 140 cm
Max. dial thickness	33 mm
Hands definition  hour  minute	Length ≤ 400 mm (from centre) Weight ≤ 400 g, unbalance ≤ 100 mNm Length ≤ 600 mm (from centre) Weight ≤ 500 g, unbalance ≤ 100 mNm
Temperature range	-30 ... +70°C
Weight	680 g
Tests and standards	EN 50121-4, EN 61000-6-3, protection class II

## 5.1 Plug wiring

### 5.1.1 RS-485

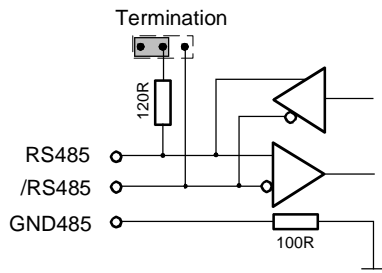

Fig. 14

### 5.1.2 DCF In/Out

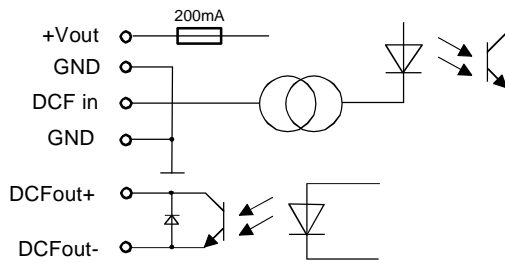

Fig. 15

Technical data subject to change without notice.







**SALES SWITZERLAND**

MOBATIME AG

Stettbachstrasse 5 • CH-8600 Duebendorf  
Tel. +41 44 802 75 75 • Fax +41 44 802 75 65  
info-d@mobatime.ch • www.mobatime.ch

MOBATIME SA

En Budron H 20 • CH-1052 Le Mont-sur-Lausanne  
Telephone +41 21 654 33 50 • Fax +41 21 654 33 69  
info-d@mobatime.ch • www.mobatime.ch

**SALES WORLDWIDE**

MOSER-BAER SA – EXPORT DIVISION

19 chemin du Champ-des-Filles • CH-1228 Plan-les-Ouates/GE  
Tel. +41 22 884 96 11 • Fax. +41 22 884 96 90  
export@mobatime.com • www.mobatime.com

**PRODUCED BY**

MOSER-BAER AG

Spitalstrasse 7 • CH-3454 Sumiswald  
www.mobatime.com

**SALES GERMANY, AUSTRIA**

BÜRK MOBATIME GmbH

Postfach 3760 D-78026 VS-Schwenningen

Steinkirchring 46 D-78056 VS-Schwenningen

Telefon +49 7720 8535 - 0 Telefax +49 7720 8535 - 11

Internet: <http://www.buerk-mobatime.de> E-Mail: [buerk@buerk-mobatime.de](mailto:buerk@buerk-mobatime.de)